

Powers™ Controls

RL 243 HL Highest and Lowest Pressure Signal Selector



Description

The RL 243 HL Highest and Lowest Pressure Signal Selector is designed to compare, select and transmit the highest and/or lowest of up to six pneumatic input signals.

The six input ports are dead-ended. The signal selector is designed for pilot duty; for most applications an amplifying relay is required.

Features

- Compact design
- Can be mounted in any position
- Bracket provided for fixed mounting

Product Number

243-0019

Specifications

Housing	4 glass-filled nylon plates and 1 steel plate
Diaphragm	Rubber with fabric
Maximum Air Pressure	30 psig (210 kPa)
Ambient Temperature - Max	140°F (60°C)
Air Connections	Barbed nipple for 1/4-inch OD polyethylene tubing
Type of Mounting	Bracket
Air Capacity High Port	29 scim
Low Port	14 scim
Air Consumption	43 scim
Dimensions	See Figure 3

Application

The highest and lowest pressure signal selector is used in applications where it is necessary to sense the output signal of a number of controllers and select the highest and lowest signal for reset purposes.

A typical example is shown in Figure 1. Four zone space thermostats modulate their respective zone dampers. The zone requiring the most heating, the lowest pressure as determined by the signal selector, resets the hot deck controller. The zone requiring the most cooling, highest pressure as determined by the signal selector, resets the cold deck controller.

Even though only four inputs are used, Ports 5 and 6 are piped to zone 4. If Ports 5 and 6 were left open, the lowest pressure output would always be 0 psi. If highest pressure is all that is required, unused ports may be left open.

The six input ports are dead-ended. That is, only supply air passes through the signal selector to the output ports. It can be used with one-pipe (bleed type) or two-pipe (relay type) thermostats. The signal selector is designed for pilot duty. For most applications, an amplifying relay will be required for both output signals.

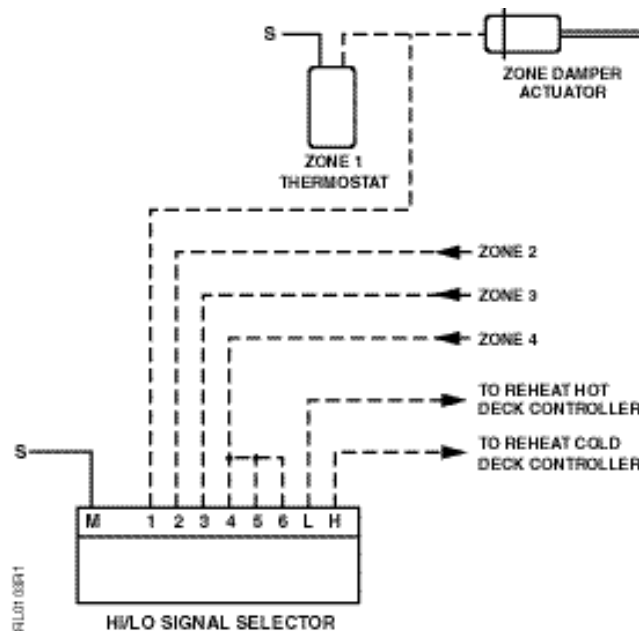

Figure 1. Typical Application.

Operation

The port identification and use is as follows. The air supply is connected to the "M" port. The input signals are connected to ports 1 through 6. The "H" port output is the highest of the input signals. The "L" port output is the lowest of the input signals.

High Signal Pressure Selection (Figure 2)

Restricted main air pressurizes chamber "A" until its value equals (slightly exceeds) the "S1" signal pressure in chamber "B" and moves the diaphragm to open the passage to chamber "C". If the "S2" signal pressure in chamber "D" is lower than the "S1" signal pressure now in chamber "C", the "S1" pressure in chamber "C" blocks the passage to chamber "E" until the pressure in chambers "C" and "A" increases to the "S2" value, at which time the diaphragm will open to pass the "S2" pressure to chamber "E". In this manner, a series of six high-pressure selections occur and the resultant highest signal pressure will appear at the "H" output port.

**Operation,
 Continued**

**Low Signal Pressure
 Selection
 (Figure 2)**

Restricted main air pressurizes the common output side of six signal comparison diaphragms, where it is exhausted to balance the applied input pressure. The lowest signal pressure will be established in all output chambers and will appear at the "L" output port.

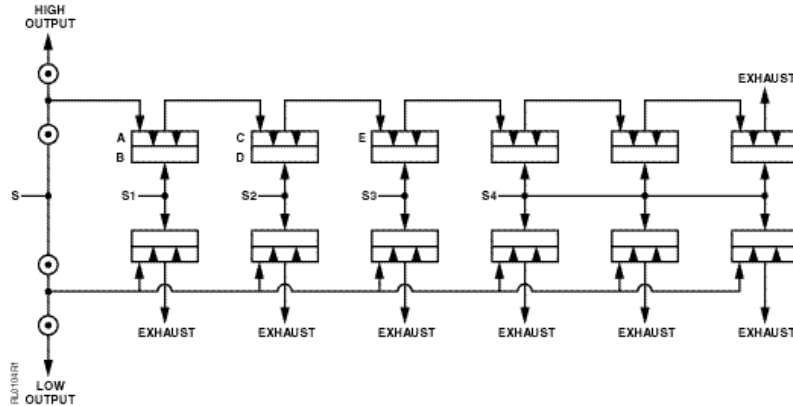

Figure 2.

**General
 Instructions**

1. To be used on control air only. DO NOT USE ON ANY OTHER MEDIUM.
2. These signal selectors will operate properly mounted in any position.

Dimensions

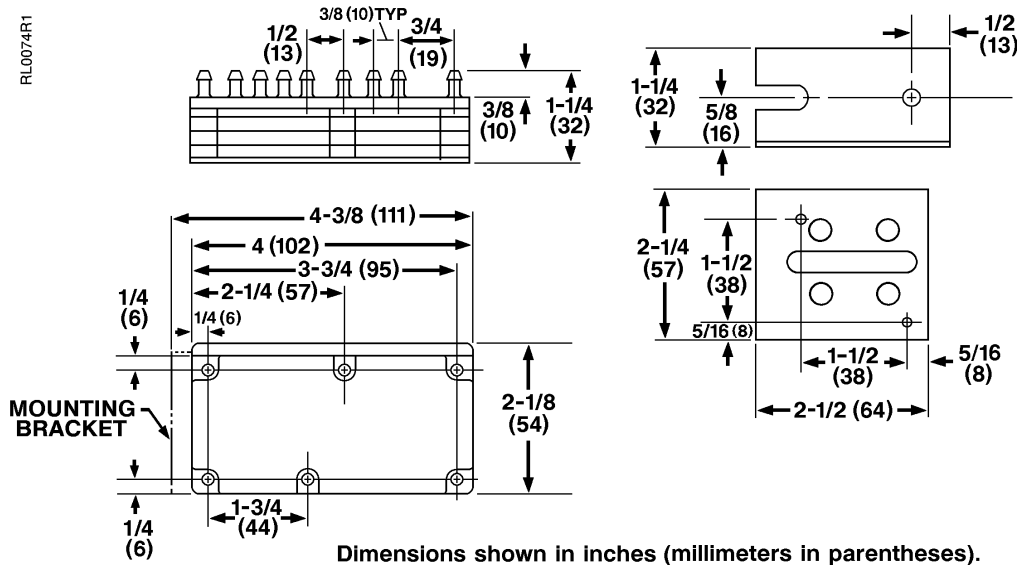

Figure 3. Signal Selector and Mounting Bracket.

Information in this publication is based on current specifications. The company reserves the right to make changes in specifications and models as design improvements are introduced. Powers is a registered trademark of Siemens Industry, Inc. Other product or company names mentioned herein may be the trademarks of their respective owners. © 2005 Siemens Industry, Inc.